



CYCLONE SEPARATOR TRAP

MODEL DC3S

Features

Cyclone separator and steam trap incorporated into one unit to provide high-quality dry steam.

1. Separator achieves condensate separation efficiency as high as 98%.
2. Self-modulating free float steam trap continuously discharges condensate as it is separated.
3. Precision ground spherical float and positive three-point seating provide a steam-tight seal, even under no-load conditions.
4. Built-in screen with large surface area ensures trouble-free operation.
5. Only one moving part, the free float, reduces valve wear and provides long, maintenance-free service life.



Specifications

Model		DC3S	
Connection		Screwed	Flanged
Size (mm)		15, 20, 25	15, 20, 25, 40, 50, 65, 80, 100
Trap Orifice No.		10, 16, 21	
Maximum Operating Pressure (MPaG)	PMO	1.0, 1.57, 2.1	
Minimum Operating Pressure (MPaG)		0.01	
Maximum Operating Temperature (°C)	TMO	220	

1 MPa = 10.197 kg/cm²
 PRESSURE SHELL DESIGN CONDITIONS (**NOT** OPERATING CONDITIONS): Maximum Allowable Pressure (MPaG) PMA: 1.57 (#10, 16), 2.1 (#21)
 Maximum Allowable Temperature (°C) TMA: 220

No.	Description	Material	JIS	ASTM/AISI*
①	Body	Ductile Cast Iron	FCD450	A536 Gr. 65-45-12
②	Separator Body (#10, 16)	Cast Iron	FC250	A126 Cl. B
	Separator Body (#21)	Ductile Cast Iron	FCD450	A536 Gr. 65-45-12
③	Trap Cover (#10, 16)	Cast Iron	FC250	A126 Cl. B
	Trap Cover (#21)	Ductile Cast Iron	FCD450	A536 Gr. 65-45-12
④	Separator (15 - 50 mm)	Cast Stainless Steel	SCS13	A351 Gr. CF-8
	Separator (65 - 100 mm)	Ductile Cast Iron	FCD450	A536 Gr. 65-45-12
⑤	Float	Stainless Steel	SUS316L	AISI316L
⑥	Float Cover (15 - 50 mm)	Cast Iron	FC250	A126 Cl. B
	Float Cover (65 - 100 mm)	Ductile Cast Iron	FCD450	A536 Gr. 65-45-12
⑦	Guide Pin	Stainless Steel	SUS304	AISI304
⑧	Trap Valve Seat	Stainless Steel	SUS420F	AISI420F
⑨	Valve Seat Gasket	Fluorine Resin	PTFE	—
⑩	Trap Cover Gasket	Fluorine Resin	PTFE	—
⑪	Wave Spring	Stainless Steel	SUS301	AISI301
⑫	Body Gasket	Fluorine Resin	PTFE	—
⑬	Screen	Stainless Steel	SUS304	AISI304
⑭	Bushing	Stainless Steel	SUS303	AISI303
⑮	Float Cover Bolt	Stainless Steel	SUS304	AISI304
⑯	Spring Washer	Stainless Steel	SUS304	AISI304
⑰	Body Bolt	Carbon Steel	S45C	AISI1045
⑱	Trap Cover Bolt	Carbon Steel	S45C	AISI1045
⑲	Nameplate	Stainless Steel	SUS304	AISI304
⑳	Baffle**	Stainless Steel	SUS304	AISI304
㉑	Baffle Bolt**	Stainless Steel	SUS304	AISI304
㉒	Baffle Nut**	Stainless Steel	SUS304	AISI304

* Equivalent ** 65 - 100, not shown # refers to the trap orifice number

CAUTION To avoid abnormal operation, accidents or serious injury, DO NOT use this product outside of the specification range. Local regulations may restrict the use of this product to below the conditions quoted.

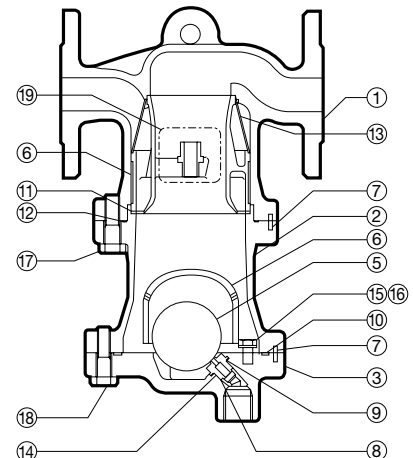

15 - 50 mm size shown, 65 - 100 mm configuration differs slightly

Dimensions

● **DC3S**
Screwed

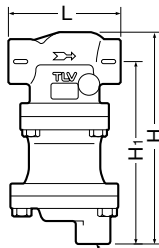

● **DC3S**
Flanged

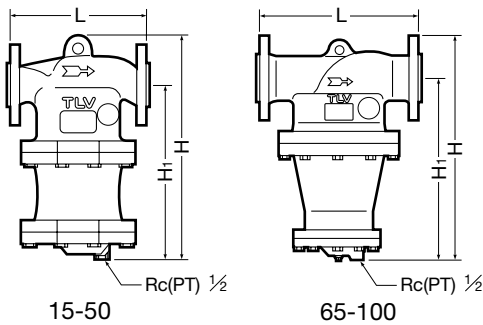

DC3S Screwed* (mm)

Size	L	H	H ₁	Weight (kg)
15	150	243	209	5.8
20				9.6
25	170	278	241	

* Rc(PT), other standards available

DC3S Flanged* (mm)

Size	L (ASME Class)		H	H ₁	Weight (approx.kg)
	150RF	300RF			
15	-	176	265	209	8.4
20	-	179			9.3
25	-	197	306	241	13
40	-	225	352	269	18
50	-	263	418	320	32
65	375	381	520	430	71
80	374	384			75
100	434	450	645	520	120

* Fits to ASME Class 150RF or 300RF
Other standards available, but length and weight may vary

Steam Flow Rate

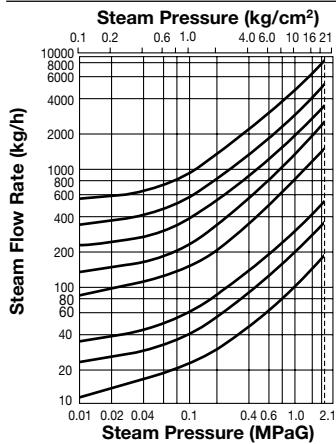

The chart on the left is used to determine the steam flow rate through the DC3S separator. It is based on a steam velocity in the piping of 30 m/sec. For other velocities, calculate the flow rate as follows:
Flow rate at v m/sec = flow rate at 30 m/sec × $\frac{v}{30}$
It is recommended that velocities not exceed 30 m/sec.

Pressure Loss

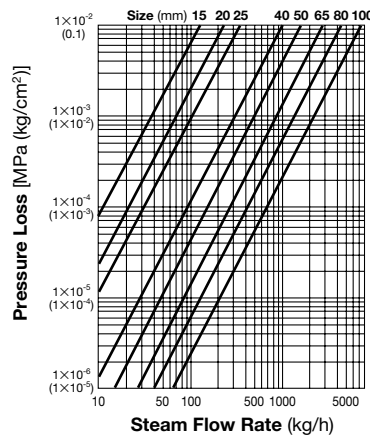

The pressure loss chart is based on a steam pressure of 1MPaG. For other pressures, multiply the steam flow rate by the correction factor given in the table below. Use the result on the pressure loss chart.

Condensate Discharge Capacity

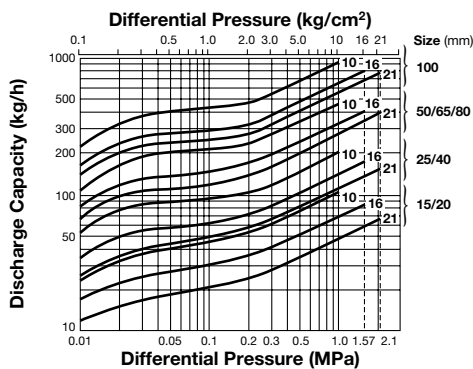

- Line numbers within the graph to the left refer to orifice numbers.
- Differential pressure is the difference between the inlet and outlet pressure of the trap.
- Capacities are based on continuous discharge of condensate 6°C below saturated steam temperature.
- Recommended safety factor: at least 1.5.

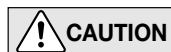

DO NOT use traps under conditions that exceed maximum differential pressure as condensate backup will occur!

Pressure [MPaG (kg/cm ² G)]	0.1 (1)	0.3 (3)	0.5 (5)	0.7 (7)	1.0 (10)	1.57 (16)	2.0 (20)	3.0 (30)
Steam Flow Rate Correction Factor	2.24	1.62	1.34	1.16	1	0.81	0.73	0.60

Manufacturer

ISO 9001/ISO 14001

TLV® CO., LTD.
Kakogawa, Japan
is approved by LRQA Ltd. to ISO 9001/14001

