



# REDUCING VALVE FOR STEAM

## MODEL MC-COSR-3/MC-COSR-16

### Features

The MC-COSR multi control valves consist of the COSR pressure reducing valve and a motorized actuator. They are used to condition steam and control either steam pressure or the temperature of processes heated by steam.

1. When combined with proprietary control algorithms of TLV's SC-F70 controller or SP-F70 programmable controller the rapid response brushless motor precisely adjusts the valve position to ensure extremely accurate pressure control, even during adverse process conditions.
2. Large surface area integral screen for pilot valve extends trouble-free service.
3. Can be used in conjunction with standard PID controllers as a replacement for a standard control valve to significantly improve T&P control performance.
4. Internal secondary pressure-sensing channel makes external sensing line unnecessary.
5. MC-COSR-16, sizes 65 mm and larger have a silencer for noise reduction.



### Specifications

Model		MC-COSR-3	MC-COSR-16	
Connection		Flanged		
Size (mm)		20 - 50	15 - 150	
Body Material**		Cast Iron		
Control Valve	Maximum Operating Pressure (MPaG) PMO	0.3	1.57	
	Maximum Operating Temperature (°C) TMO	220		
	Primary Pressure Range (MPaG)	0.1 - 0.3	0.2 - 1.57	
	Adjustable Pressure Range (all conditions must be met)	0.01 - 0.05 MPaG	Within 10-84% of primary pressure but with a minimum pressure of 0.03 MPaG	
	Minimum Adjustable Flow Rate	5% of rated flow rate	5% of rated flow rate (For 65 mm - 150 mm: 10% of rated flow rate) steam	
Actuator*	Fluid	steam		
	Input	Valve Opening Input	4 - 20 mA DC (input impedance 250 MΩ)	
	Power	Line Voltage	Free between AC 100 V and AC 240V (50/60 Hz)	
		Power Consumption	max. 75 VA	
		Insulation	Between each terminal and ground: DC 500 V min. 100MΩ	
	Environment	Withstand Voltage	Between power terminal and ground terminal: AC 1500 V for 1 minute or AC 1800 V for 1 second	
		Ambient Temperature	0 - 50 °C	
		Ambient Humidity	10 - 90 % RH (without dew)	
		Vibration Resistance	max. 0.5 G	
	Others	Water Resistance	Rain-resistant	
		Drive System	Positional control by DC brushless motor	
Thermal Protection		Built-in overcurrent protection circuit		
Open/ Close Time		Fully closed → fully open: approximately 15 seconds		
Emergency Action		When operation signal input is cut off: fully closed		
Manual Operation	Possible with power OFF			

Note: MC-COSR-3 cannot be used for temperature control applications.

1 MPa = 10.197 kg/cm<sup>2</sup>

\* Ex-proof type actuator is available in UL, BASEEFA or Japanese standard

\*\* Stainless steel body available for 15 - 50 mm on request

#### PRESSURE SHELL DESIGN CONDITIONS (NOT OPERATING CONDITIONS):

Maximum Allowable Pressure (MPaG) PMA: 1.57

Maximum Allowable Temperature (°C) TMA: 220



To avoid abnormal operation, accidents or serious injury, DO NOT use this product outside of the specification range. Local regulations may restrict the use of this product to below the conditions quoted.

Capacity Table

MC-COSR-16 with internal secondary pressure-sensing channel (factory standard) (kg/h)

Primary Steam Press. MPaG	Secondary (Set) Steam Press. MPaG	Nominal Valve Size (mm)										
		15	20	25	32	40	50	65	80	100	125	150
0.2	*0.13	170	240	340	540	670	920	1460	2090	3150	4440	6780
	0.11	180	260	370	570	720	990	1570	2250	3400	4770	7290
	0.1	185	270	380	580	730	1010	1610	2310	3480	4990	7480
	0.07	60	160	360	560	700	1000	1600	2300	3470	4970	7470
	**0.03	50	140	340	520	660	990	1590	2290	3460	4870	7430
0.3	*0.23	190	280	400	600	710	1090	1740	2500	3760	5290	8090
	0.2	200	290	430	620	800	1240	1790	2820	4250	5980	9140
	0.15	210	310	450	660	880	1370	2180	3120	4700	6620	10100
	0.1	80	190	400	600	840	1300	2080	2980	4480	6310	9640
	**0.03	50	140	340	520	740	1150	1830	2630	3950	5560	8490
0.4	*0.33	200	290	410	610	800	1250	1980	2840	4280	6030	9200
	0.3	220	310	450	650	920	1420	2270	3250	4900	6890	10500
	0.25	230	320	480	690	1040	1610	2570	3690	5560	7810	11900
	0.2	240	350	520	730	1130	1750	2790	3990	6020	8290	12900
	0.1	80	280	440	620	960	1490	2370	3390	5110	7190	11000
	**0.04	60	150	390	550	850	1310	2090	3000	4510	6340	9620
0.5	*0.42	220	320	370	610	940	1460	2320	3330	5010	7050	10800
	0.4	240	340	470	660	1030	1590	2530	3630	5470	7690	11800
	0.3	260	380	590	820	1270	1980	3050	4510	6800	9560	14600
	0.25	270	400	620	870	1350	2080	3320	4760	7170	9950	15400
	0.15	170	320	520	720	1120	1730	2760	3950	5950	8370	12800
	**0.05	60	150	410	570	890	1380	2190	3140	4730	6660	10200
0.6	*0.5	250	350	520	720	1120	1740	2770	3970	5980	8410	12900
	0.4	280	410	660	920	1420	2210	3520	5040	7590	10680	16300
	0.35	290	440	690	970	1500	2330	3710	5320	8010	11300	17200
	0.3	300	460	720	1010	1560	2420	3860	5530	8330	11600	17900
	0.15	170	320	480	670	1030	1600	2550	3800	5500	7730	11800
	**0.06	60	150	420	590	920	1420	2260	3250	4890	6870	10500
0.7	*0.58	250	370	600	840	1300	2020	3220	4610	6940	9770	14900
	0.5	290	450	720	1010	1560	2420	3850	5520	8320	11700	17900
	0.4	330	500	800	1110	1720	2670	4260	6110	9200	12900	19800
	0.35	350	510	820	1150	1780	2750	4390	6290	9480	13200	20400
	0.2	200	380	610	850	1310	2040	3250	4660	7010	9860	15100
	**0.07	70	230	430	600	930	1450	2310	3310	4980	6930	10700
0.8	*0.67	280	410	670	930	1440	2230	3550	5100	7620	10800	16500
	0.6	300	480	780	1090	1680	2610	4160	5970	8980	12600	19300
	0.5	340	540	870	1220	1890	2930	4670	6690	10100	14200	21600
	0.4	400	570	920	1290	1990	3090	4920	7060	10600	14900	22800
	0.2	200	380	610	850	1310	2040	3250	4660	7010	9860	15100
	**0.08	70	160	410	580	900	1390	2220	3180	4780	6730	10300
1.0	*0.84	310	500	810	1130	1750	2720	4330	6210	9360	13200	20100
	0.7	390	630	1010	1410	2180	3380	5390	7730	11600	16400	25000
	0.6	470	670	1080	1510	2340	3620	5780	8280	12500	17500	26800
	0.5	500	700	1120	1560	2420	3750	5990	8580	12900	18100	27800
	0.3	300	460	740	1030	1600	2480	3950	5790	8520	12000	18300
	**0.15	170	320	480	680	970	1510	2390	3430	5170	7270	11100
1.2	*1.0	350	610	980	1360	2110	3270	5220	7480	11300	15800	24200
	0.8	500	760	1230	1710	2650	4110	6560	9400	14200	19900	30400
	0.7	570	800	1290	1800	2780	4310	6870	9850	14800	20900	31900
	0.6	600	820	1320	1840	2850	4420	7050	10100	15200	21300	32700
	0.5	500	680	1090	1530	2370	3670	5850	8380	12600	17800	27100
	**0.35	360	550	890	1240	1930	2980	4760	6820	10300	14400	22100
1.4	*1.17	410	700	1120	1570	2430	3760	6000	8590	12400	18200	27800
	1.0	540	840	1360	1900	2940	4550	7260	10400	15600	22000	33700
	0.8	670	980	1490	2300	3220	4990	7950	11400	17200	24100	36900
	0.7	730	1050	1520	2450	3280	5090	8110	11600	17500	24500	37600
	0.6	600	840	1240	2000	2690	4170	6650	9530	14300	20200	30800
	**0.55	550	770	1130	1580	2450	3790	6040	8660	13000	18300	28000
1.57	*1.32	420	770	1240	1730	2670	4140	6600	9460	14200	20000	30600
	1.0	730	1100	1650	2400	3560	5520	8800	12600	19000	26700	40800
	0.9	790	1200	1750	2600	3650	5660	9030	12900	19500	27400	41900
	0.8	880	1300	2000	2700	3710	5750	9170	13100	19800	27800	42500
	**0.75	820	1250	1800	2600	3400	5260	8390	12000	18100	25500	38900

\* Maximum adjustable secondary pressure \*\* Minimum adjustable secondary pressure

1 MPa = 10.197 kg/cm<sup>2</sup>

**Capacity Table**

**MC-COSR-16 with external secondary pressure-sensing line (optional) (kg/h)**

Primary Steam Press. MPaG	Secondary (Set) Steam Press. MPaG	Nominal Valve Size (mm)										
		15	20	25	32	40	50	65	80	100	125	150
0.2	*0.13	170	240	340	540	670	920	1460	2090	3150	4440	6780
	0.11	180	260	370	570	720	990	1570	2250	3400	4770	7290
	**0.03 - 0.1	185	270	380	580	730	1010	1610	2310	3480	4990	7480
0.3	*0.23	190	280	400	600	710	1090	1740	2500	3760	5290	8090
	0.2	200	290	430	620	800	1240	1790	2820	4250	5980	9140
	**0.03 - 0.15	210	310	450	660	880	1370	2180	3120	4700	6620	10100
0.4	*0.33	200	290	410	610	800	1250	1980	2840	4280	6030	9200
	0.3	220	310	450	650	920	1420	2270	3250	4900	6890	10500
	0.25	230	320	480	690	1040	1610	2570	3690	5560	7810	11900
0.5	**0.04 - 0.2	240	350	520	730	1130	1750	2790	3990	6020	8290	12900
	*0.42	220	320	370	610	940	1460	2320	3330	5010	7050	10800
	0.4	240	340	470	660	1030	1590	2530	3630	5470	7690	11800
	0.3	260	380	590	820	1270	1980	3050	4510	6800	9560	14600
0.6	**0.05 - 0.25	270	400	620	870	1350	2080	3320	4760	7170	9950	15400
	*0.5	250	350	520	720	1120	1740	2770	3970	5980	8410	12900
	0.4	280	410	660	920	1420	2210	3520	5040	7590	10680	16300
	0.35	290	440	690	970	1500	2330	3710	5320	8010	11300	17200
0.7	**0.06 - 0.3	300	460	720	1010	1560	2420	3860	5530	8330	11600	17900
	*0.58	250	370	600	840	1300	2020	3220	4610	6940	9770	14900
	0.5	290	450	720	1010	1560	2420	3850	5520	8320	11700	17900
	0.4	330	500	800	1110	1720	2670	4260	6110	9200	12900	19800
0.8	**0.07 - 0.35	350	510	820	1150	1780	2750	4390	6290	9480	13200	20400
	*0.67	280	410	670	930	1440	2230	3550	5100	7620	10800	16500
	0.6	300	480	780	1090	1680	2610	4160	5970	8980	12600	19300
	0.5	340	540	870	1220	1890	2930	4670	6690	10100	14200	21600
1.0	**0.08 - 0.4	400	570	920	1290	1990	3090	4920	7060	10600	14900	22800
	*0.84	310	500	810	1130	1750	2720	4330	6210	9360	13200	20100
	0.7	390	630	1010	1410	2180	3380	5390	7730	11600	16400	25000
	0.6	470	670	1080	1510	2340	3620	5780	8280	12500	17500	26800
1.2	**0.15 - 0.5	500	700	1120	1560	2420	3750	5990	8580	12900	18100	27800
	*1.0	350	610	980	1360	2110	3270	5220	7480	11300	15800	24200
	0.8	500	760	1230	1710	2650	4110	6560	9400	14200	19900	30400
	0.7	570	800	1290	1800	2780	4310	6870	9850	14800	20900	31900
1.4	**0.35 - 0.6	600	820	1320	1840	2850	4420	7050	10100	15200	21300	32700
	*1.17	410	700	1120	1570	2430	3760	6000	8590	12400	18200	27800
	1.0	540	840	1360	1900	2940	4550	7260	10400	15600	22000	33700
	0.8	670	980	1490	2300	3220	4990	7950	11400	17200	24100	36900
1.57	**0.55 - 0.7	730	1050	1520	2450	3280	5090	8110	11600	17500	24500	37600
	*1.32	420	770	1240	1730	2670	4140	6600	9460	14200	20000	30600
	1.0	730	1100	1650	2400	3560	5520	8800	12600	19000	26700	40800
	0.9	790	1200	1750	2600	3650	5660	9030	12900	19500	27400	41900
1.57	**0.75 - 0.8	880	1300	2000	2700	3710	5750	9170	13100	19800	27800	42500

\* Maximum adjustable secondary pressure    \*\* Minimum adjustable secondary pressure    1 MPa = 10.197 kg/cm<sup>2</sup>

**Cv & Kvs Values**

	Nominal Valve Size (mm)										
	15	20	25	32	40	50	65	80	100	125	150
Cv (US)	3.8	6.9	11.1	15.5	24.0	37.2	59.3	85.0	128	180	275
Cv (UK)	3.2	5.7	9.2	12.9	20.0	31.0	49.4	70.8	107	150	229
Kvs (DIN)	3.3	5.9	9.5	13.3	20.6	31.9	50.8	72.9	110	154	236

**CAUTION** The Cv & Kvs values shown are for the valve in the full fail open position. These values are not to be used for MC-COSR sizing, and instead may be used as one of the factors in calculations for safety valve selection.

**Capacity Table**

**MC-COSR-3 with internal or external secondary pressure-sensing channel or line**

Pressure Sensing Method	Primary Pressure (MPaG)	Secondary (Set) Pressure (MPaG)	Normal valve Size (mm)				
			20	25	32	40	50
Cv Values		Cv (US)	6.9	11.1	15.5	24.0	37.2
		Cv (UK)	5.7	9.2	12.9	20.0	31.0
		Kvs (DIN)	5.9	9.5	13.3	20.6	31.9
Internal sensing channel (factory standard)	0.1 to less than 0.2	*0.05	120	180	540	750	950
		0.04	130	190	520	700	920
		0.03	135	195	510	680	900
		0.02	140	200	390	500	690
		**0.01	100	180	290	380	500
	0.2 - 0.3	*0.05	240	340	540	750	950
		0.04	230	330	520	700	920
		0.03	220	320	510	680	900
		0.02	160	250	390	500	690
		**0.01	100	180	290	380	500
External sensing line (optional)	0.1 to less than 0.2	*0.05 - **0.01	120	180	540	750	950
	0.2 - 0.3	*0.05 - **0.01	240	340	510	750	950

\* Minimum adjustable pressure    \*\* Maximum adjustable pressure

1 MPa = 10.197 kg/cm<sup>2</sup>



The Cv & Kvs values shown are for the valve in the full fail open position. These values are not to be used for MC-COSR sizing, and instead may be used as one of the factors in calculations for safety valve selection.

**Dimensions**

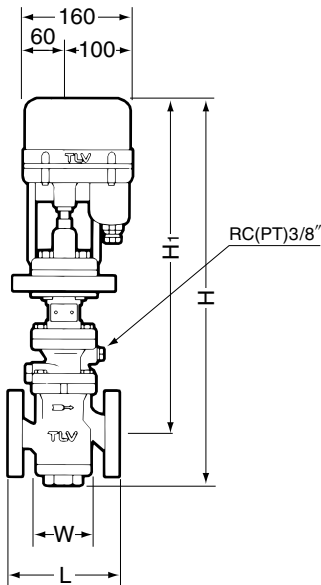

DN 15 - 25 shown. Configuration of larger sizes differs slightly.

**MC-COSR-3 Flanged\* (mm)**

Size	L(ASME Class)		H	H <sub>1</sub>	Weight (approx. kg)
	150RF	300RF			
20	182	182	582	510	16
25	188	192			18
32	220	220	610	520	24
40		224			25
50	255	261	637	540	32

\* Other standards available, but length and weight may vary

**MC-COSR-16 Flanged\* (mm)**

Size	L(ASME Class)		H	H <sub>1</sub>	Weight (approx. kg)
	150RF	300RF			
15	170	170	582	510	17
20	182	182			
25	188	192	610	520	19
32	220	220			
40	220	224	637	540	24
50		255			
65	372	378	778	635	62
80	374	384			66
100	434	450	857	672	102
125	434	456			126
150	600	622	1035	755	211

\* Other standards available, but length and weight may vary

Manufacturer

ISO 9001/ISO 14001

**TLV**® CO., LTD.  
Kakogawa, Japan

is approved by LRQA Ltd. to ISO 9001/14001

