



FREE FLOAT STEAM TRAP

MODEL J3X

FREE FLOAT STEAM TRAP WITH THERMOSTATIC AIR VENTING

Features

A reliable and durable free float steam trap with tight shut-off for use on small process equipment.

1. Thermostatic capsule with "fail open" feature vents air automatically until close-to-steam temperature, for rapid start-up.
2. Hot air during operation can also be vented allowing increased productivity and even heating.
3. Only one moving part, the free float, eliminates concentrated valve wear and provides long maintenance-free service life.
4. Easy, inline access to internal parts simplifies cleaning and reduces maintenance costs.
5. Built-in screen with large surface area ensures trouble-free operation.
6. Self-modulating free float provides continuous, smooth, low velocity condensate discharge as process loads vary.



Specifications

Model		J3X	JF3X
Connection		Screwed	Flanged
Size (mm)		15, 20, 25	
Orifice No.		2, 5, 8, 10, 21	2, 5, 8, 10, 16
Maximum Operating Pressure (MPaG)	PMO	0.2, 0.5, 0.8, 1.0, 2.1	0.2, 0.5, 0.8, 1.0, 1.57
Maximum Differential Pressure (MPa)	ΔPMX	0.2, 0.5, 0.8, 1.0, 2.1	0.2, 0.5, 0.8, 1.0, 1.57
Minimum Operating Pressure (MPaG)		0.01	
Maximum Operating Temperature (°C)	TMO	220	
Subcooling of X-element Fill (°C)		up to 6	
Type of X-element		B	

PRESSURE SHELL DESIGN CONDITIONS (**NOT** OPERATING CONDITIONS):

Maximum Allowable Pressure (MPaG) PMA: 2.1 (J3X), 1.57 (JF3X)

Maximum Allowable Temperature (°C) TMA: 220

1 MPa = 10.197 kg/cm²



To avoid abnormal operation, accidents or serious injury, **DO NOT** use this product outside of the specification range. Local regulations may restrict the use of this product to below the conditions quoted.

No.	Description	Material	JIS	ASTM/AISI*
①	Body (J3X)	Ductile Cast Iron	FCD450	A536 Gr. 65-45-12
	Body (JF3X)	Cast Iron	FCV410	A842 Gr. 400
②	Cover	Ductile Cast Iron	FCD450	A536 Gr. 65-45-12
③ F	Float	Stainless Steel	SUS316L	AISI316L
④	Orifice Holder Plug	Carbon Steel	S25C	AISI1025
⑤ MR	Orifice Plug Gasket	Fluorine Resin	PTFE	—
⑥ R	Orifice	Stainless Steel	SUS420F	AISI420F
⑦ MR	Orifice O-Ring	Synthetic Rubber	EPR	D2000CA
⑧ R	Screen outside/inside	Stainless Steel	SUS304/430	AISI304/430
⑨ MR	Cover Gasket	Fluorine Resin	PTFE	—
⑩	Nameplate	Stainless Steel	SUS304	AISI304
⑪ R	Float Cover	Stainless Steel	SUS304	AISI304
⑫ R	X-element Guide	Stainless Steel	SUS304	AISI304
⑬ R	X-element	Stainless Steel	—	—
⑭ R	Spring Clip	Stainless Steel	SUS304	AISI304
⑮ R	Air Vent Valve Seat	Stainless Steel	SUS420F	AISI420F
⑯	Connector	Stainless Steel	SUS416	AISI416
⑰	Cover Bolt	Carbon Steel	S45C	AISI1045
⑱	Plug	Carbon Steel	S25C	AISI1025
⑲ MR	Plug Gasket	Fluorine Resin	PTFE	—
⑳	Drain Plug	Carbon Steel	S25C	AISI1025
㉑ MR	Drain Plug Gasket	Soft Iron	SUYP	AISI1010

* Equivalent

Replacement kits available: (M) maintenance parts, (R) repair parts, (F) float

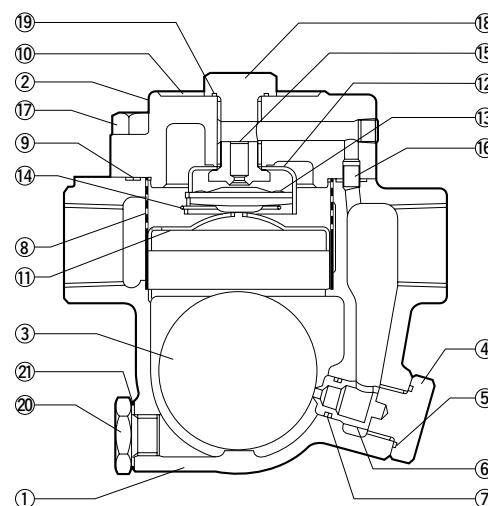

Optional lock release valve available for special applications.

Copyright © TLV

Dimensions

● **J3X**

Screwed

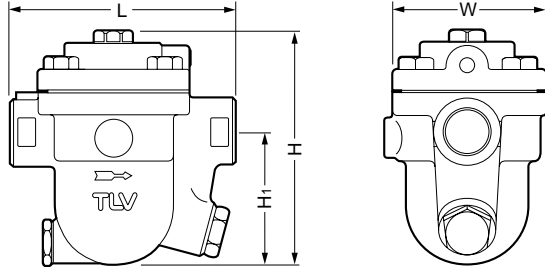

J3X Screwed*

(mm)

Size	L	H	H ₁	W	Weight (kg)
15	120	130	75	80	2.7
20			73		2.8
25		137	75		3

* Rc(PT), other standards available

● **JF3X**

Flanged

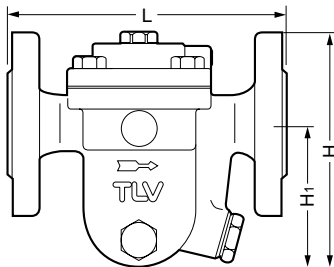

JF3X Flanged

(mm)

Size	L				H	H ₁	W	Weight* (kg)
	ASME Class							
	125FF	(150RF)	250RF	(300RF)				
(15)	-	175	-	175	127	79	80	3.8
(20)	-	195	-	195	133	89		5.1
25	203	215	215	219	140	91		6.0

() No ASME standard exists for cast iron; machined to fit steel flanges
 Class 125 FF can connect to 150 RF, 250 RF can connect to 300RF
 Other standards available, but length and weight may vary
 * Weight is for Class 300 RF

Discharge Capacity

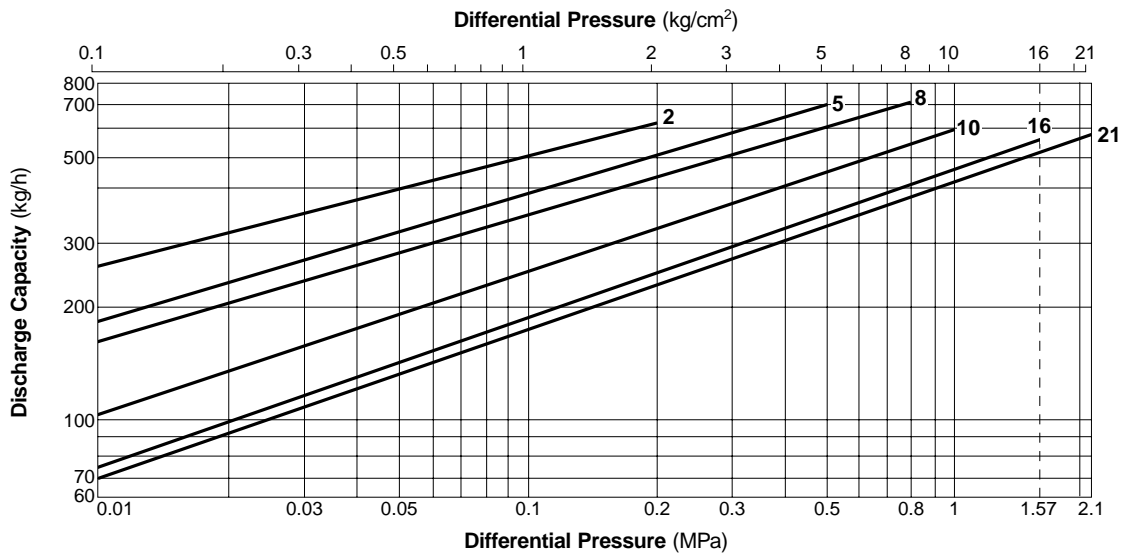

1. Line numbers within the graph refer to orifice numbers.
2. Differential pressure is the difference between the inlet and outlet pressure of the trap.
3. Capacities are based on continuous discharge of condensate 6°C below saturated steam temperature.
4. Recommended safety factor: at least 1.5.



DO NOT use traps under conditions that exceed maximum differential pressure, as condensate backup will occur!

Manufacturer

ISO 9001/ISO 14001

TLV® CO., LTD.
Kakogawa, Japan

is approved by LRQA Ltd. to ISO 9001/14001

