



PowerTrap®

MODEL GT10L

Features

Pumping trap with inbuilt steam trap for a wide range of applications: drainage of low capacity heat exchangers, flash steam recovery systems and reservoirs that may often operate in a vacuum.

1. Handles high temperature condensate without cavitation.
2. No electric power or additional level controls required, hence **INTRINSICALLY SAFE**.
3. Pump will operate with a low filling head.
4. Easy, inline access to internal parts simplifies cleaning and reduces maintenance costs.
5. High quality stainless steel internals ensure reliability.
6. Compact design permits installation in a limited space.
7. Inbuilt steam trap eliminates the need for separate equipment, thus reducing installation costs.

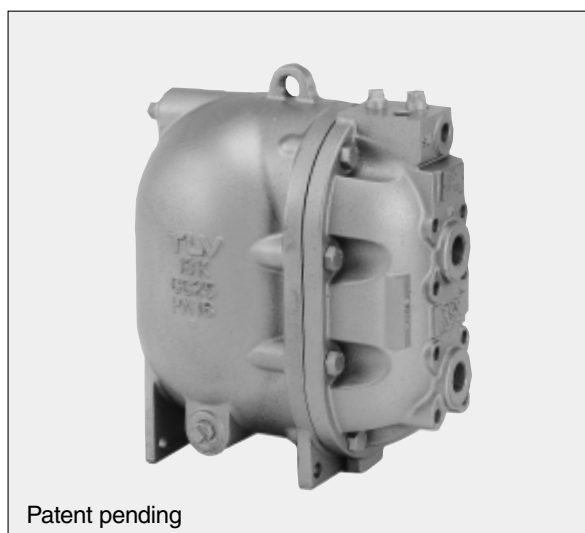

Specifications

Model	GT10L		
Connection: Pumped Medium Inlet & Outlet	Screwed Rc (PT)*		Flanged** JIS 10/16K*
Motive Medium & Pump Exhaust		Screwed Rc (PT)*	
Size (mm): Pumped Medium: Inlet × Outlet	25 × 25, 40 × 25		25 × 25
Motive Medium Inlet			15
Pump Exhaust Outlet			15
Maximum Operating Pressure (MPaG) PMO			1.05
Maximum Operating Temperature (°C) TMO			185
Motive Medium Pressure Range (MPaG)			0.03 – 1.05
Volume of Each Discharge Cycle (litre)			approximately 6
Motive Medium	Steam, compressed air, nitrogen or other non-flammable, non-toxic gas		
Pumped Medium	Steam condensate, water or other non-flammable, non-toxic fluid with a specific gravity of 0.85–1		

* Other standards available ** For details of flange connection, see picture at bottom right

1 MPa = 10.197 kg/cm²

PRESSURE SHELL DESIGN CONDITIONS (NOT OPERATING CONDITIONS):

Maximum Allowable Pressure (MPaG) PMA: 1.57 (Cast Iron), 2.1 (Cast Steel)

Maximum Allowable Temperature (°C) TMA: 220



To avoid abnormal operation, accidents or serious injury, **DO NOT** use this product outside of the specification range. Local regulations may restrict the use of this product to below the conditions quoted.

No.	Description	Material	JIS	ASTM/AISI ⁽¹⁾
①	Body	Cast Iron	FC250	A126 Cl. B
		Cast Steel ⁽²⁾	SCPH2	A216 Gr. WCB
②	Cover	Cast Iron	FC250	A126 Cl. B
		Cast Steel ⁽²⁾	SCPH2	A216 Gr. WCB
③	Cover Gasket	Graphite Compound	—	—
④	Float	Stainless Steel	SUS316L	AISI316L
⑤	Snap-action Unit	Stainless Steel	—	—
⑥	Motive Medium Intake Valve Unit:			
	Intake Valve	Stainless Steel	SUS440C	AISI440C
	Valve Seat	Stainless Steel	SUS420F	AISI420F
⑦	Exhaust Valve Unit:			
	Exhaust Valve	Stainless Steel	SUS440C	AISI440C
	Valve Seat	Stainless Steel	SUS420F	AISI420F
⑧	Trap Unit	Stainless Steel	—	—
⑨	TLV CK3MG Check Valve ^{(3) (5)}	Cast Stainless Steel	SCS13A	A351 Gr. CF-8
	TLV CKF3M Check Valve ^{(4) (5)}	Cast Stainless Steel	SCS13A	A351 Gr. CF-8

1) Equivalent 2) Option: Cast stainless steel 3) Screwed 4) Flanged 5) Not shown

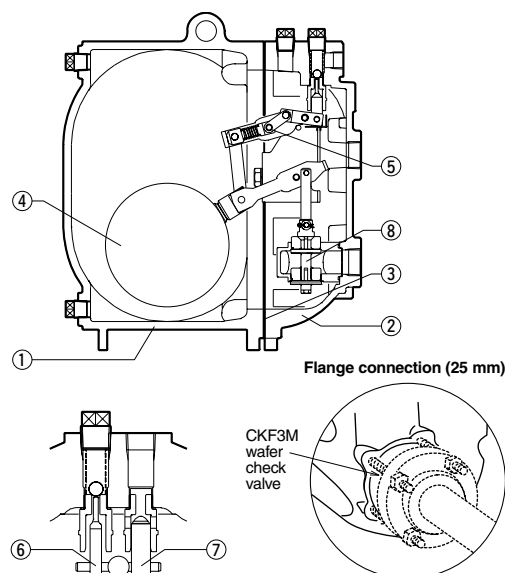

Copyright © TLV

Discharge Capacity

A:

Connection:	Screwed
Inlet size:	25 mm
Outlet size:	25 mm
Check Valve:	CK3MG
Inlet:	25 mm
Outlet:	25 mm
Filling Head:	630 mm

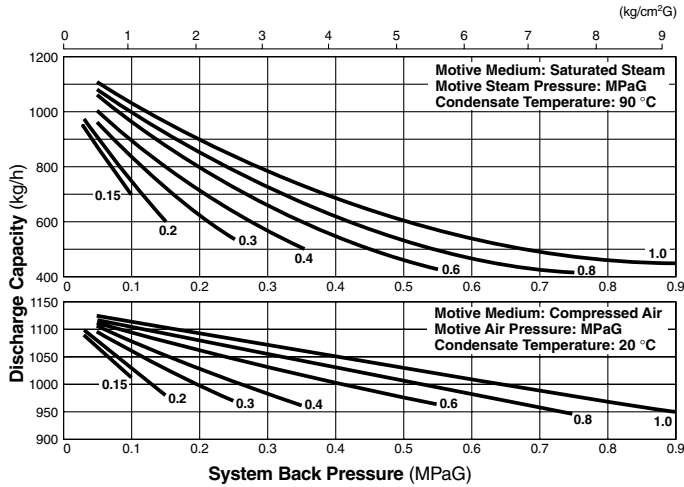

● CORRECTION FACTOR

For GT10L with 25 mm CK3MG inlet & outlet check valves, installed with filling head other than 630 mm (minimum filling head: 450 mm)

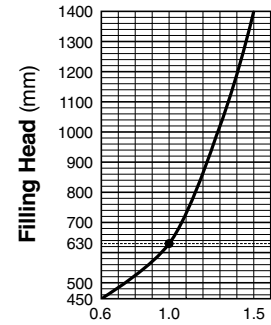

B:

Connection:	Flanged
Inlet size:	25 mm
Outlet size:	25 mm
Check Valve:	CKF3M
Inlet:	25 mm
Outlet:	25 mm
Filling Head:	630 mm

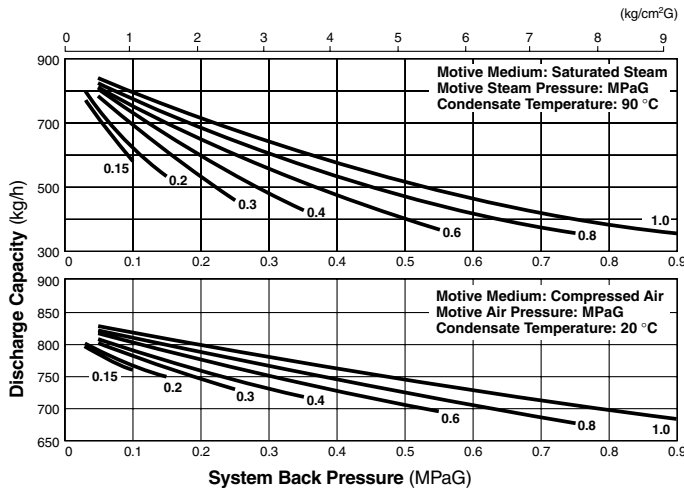

● CORRECTION FACTOR

For GT10L with 25 mm CKF3M inlet & outlet check valves, installed with filling head other than 630 mm (minimum filling head: 550 mm)

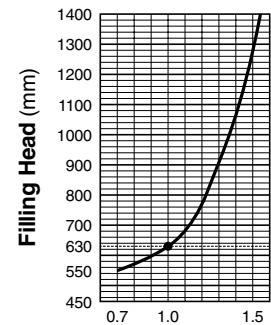

C:

Connection:	Screwed
Inlet size:	40 mm
Outlet size:	25 mm
Check Valve:	CK3MG
Inlet:	40 mm
Outlet:	25 mm
Filling Head:	630 mm

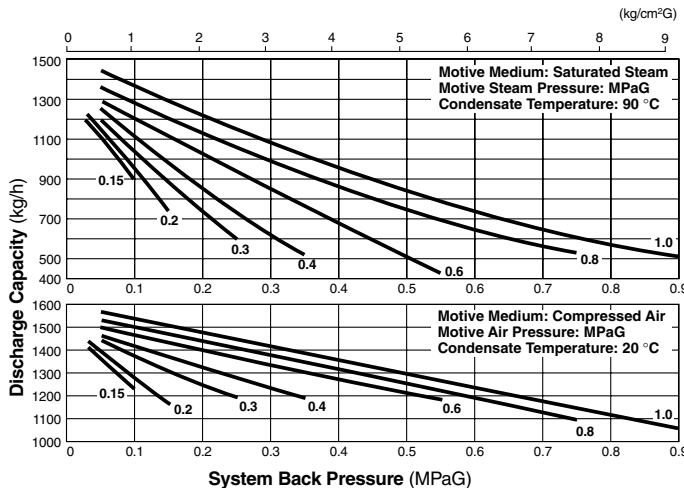

● CORRECTION FACTOR

For GT10L with 40 mm inlet, and 25 mm outlet CK3MG check valve, with filling head other than 630 mm (minimum filling head: 450 mm)

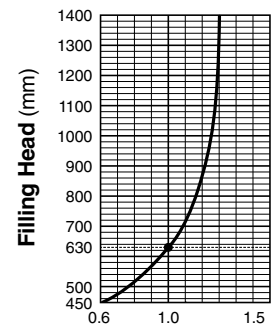

FILLING HEAD AND PRESSURES

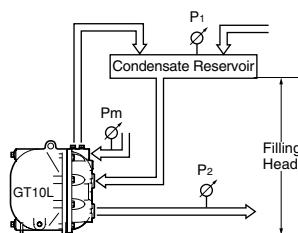

NOTE:

- The flow rate is determined by the motive medium, motive medium pressure (Pm) and back pressure (P2). Make sure that: flow rate × correction factor > required flow rate.
- To achieve the above capacities with the standard GT10L configuration, TLV CK3MG or CKF3M check valves must be used at pumped medium inlet and outlet, and size of connection and check valve must be identical.
- When the motive medium is steam, motive steam pressure minus back pressure must be greater than 0.05 MPaG.
- In closed system applications, the motive medium must be compatible with the liquid being pumped. If a non-condensable gas such as air or nitrogen is used as the motive medium, consult TLV for assistance.
- A strainer must be installed at the motive medium and pumped medium inlets. A check valve must be installed at both the pumped medium inlet and outlet.

Dimensions

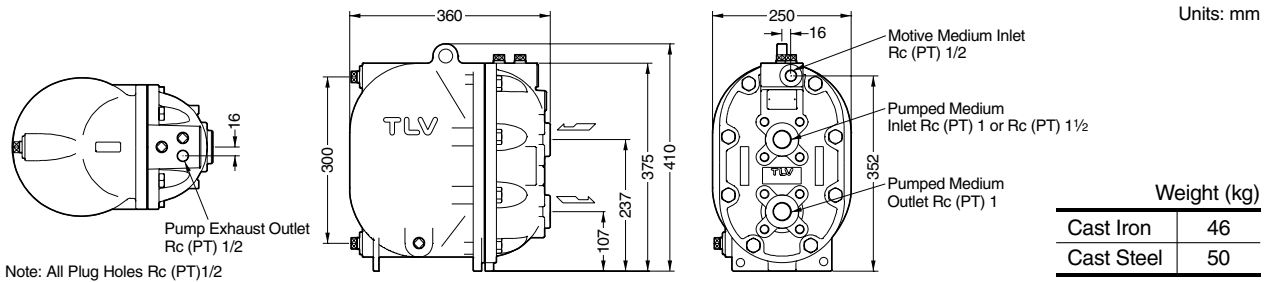

Size of Reservoir

The reservoir must have a capacity sufficient to store the condensate produced during the PowerTrap operation and discharge.

Size of reservoir; flash steam is not involved

Amount of condensate kg/h	Reservoir diameter (mm) and length (m)						
	40	50	80	100	150	200	250
300	1.2 m	0.7					
400	1.5	1.0					
500	2.0	1.2	0.5				
600		1.5	0.6				
800		2.0	0.8	0.5			
1000			1.0	0.7			
1500			1.5	1.0			
2000			2.0	1.3	0.6		
3000				2.0	0.9	0.5	
4000					1.2	0.7	
5000					1.4	0.8	0.5
6000					1.7	1.0	0.6
7000					2.0	1.2	0.7
8000						1.3	0.8
9000						1.5	0.9
10000						1.7	1.0

Reservoir length can be reduced by 50% when the motive pressure (Pm) divided by the back pressure (P2) equals 2 or greater (when $P_m \div P_2 \geq 2$).

Steam or Air Consumption

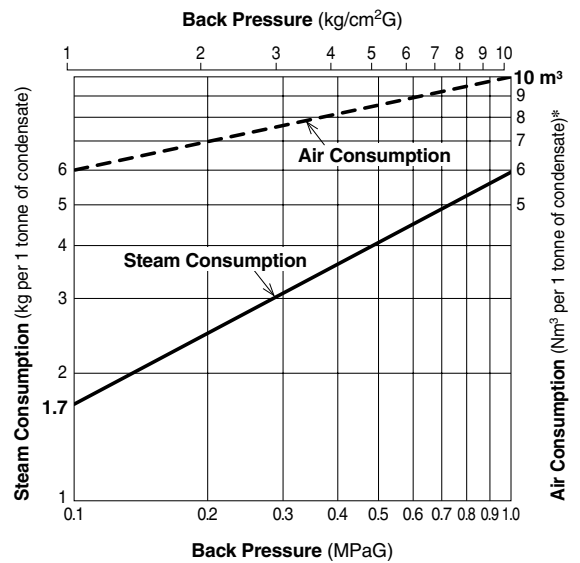

* Equivalent consumption of standard air (air at 20 °C under atmospheric pressure)

GT10L Steam Trap Capacity

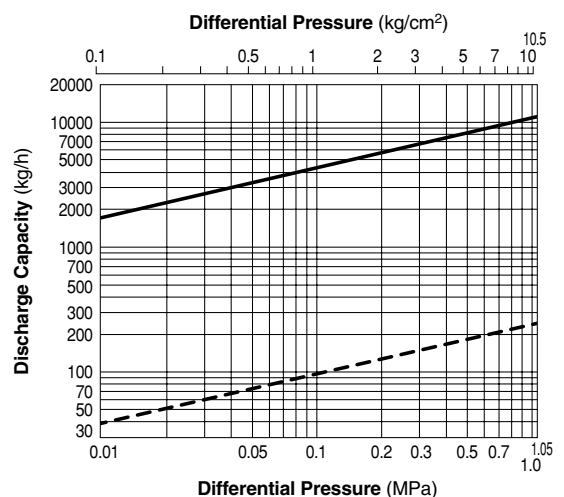

- Capacities are based on continuous discharge of condensate 6 °C below steam temperature.
- Differential pressure is the difference between inlet and outlet pressure of the trap.
 - : Capacity of GT10L as a steam trap ($P_1 > P_2$). Instantaneous condensate loads above the rated trap capacity will cause the pump to cycle and therefore reduce the discharge capacity.
 - - - : Minimum amount of condensate required to prevent steam leakage.

Memo:

Copyright © TLV
(O)

Manufacturer
TLV® CO., LTD.
Kakogawa, Japan
is approved by LRQA Ltd. to ISO 9001/14001

<http://www.tlv.com>

ISO 9001/ISO 14001



The image shows two circular certification logos. The left one is for ISO 9001 and the right one is for ISO 14001. Both logos feature a stylized 'R' in the center and the text 'REGISTERED QUALITY ASSURANCE' around the perimeter.